



THE WOODSMITHS

working with nature

contents

About us	1
Sustainability	2
Custom Tops	3
Finger Jointed Tops	4
Eco Bamboo Tops	5
Our Timber Coatings	6
Maintenance and FAQ's	7
The Process	8
Solid Surface Tops	9
Vanities	10
Solid Wood Doors	11
Aluminium Doors	12
Shelving	13
Stair Treads, Balustrades & Handrails	14
Screens, & Wall Linings	16
Bespoke Tables	17
Butcher's Block	18
Stain Colours	19
Timber Selection	20



THE WOODSMITHS

FreePhone: 0800 149 663
sales@woodsmiths.co.nz
www.woodsmiths.nz



THE WOODSMITHS

about us

We are a family business founded in 1990 dedicated to creating enduring top-quality products, individually handcrafted for homes, hospitality and corporate spaces.

Sustainability: Timber is a healthy and renewable material, free from compounds such as silica. Timber is the perfect material for interiors.

Upcycling: We have become the number one finishing shop for resurfacing older benchtops all over New Zealand. Taking tops that have been in use for 30 years and more and refurbishing them, ready for a new life of wear and tear. Recycled and reclaimed timbers are also used in projects.

Community: Having our roots in a small rural community and being a family-owned business, we firmly believe in helping others wherever possible. That's why we're so proud to be a supporter of RRT charity and the awesome work they do across the globe. We also work with NEST and are proud to support the northland rescue helicopter and what they do to care for the Northland community every day.

Why Choose Us

- ④ Over 30 years of experience in working with solid wood and trusted by designers, joiners and architects all over Australasia.
- ④ All our products are made in our factory in Northland, New Zealand
- ④ Comprehensive Warranties
- ④ Commitment to highest quality
- ④ Our custom approach to projects allows us to give personal service



Sustainability

Having our background in forestry and milling we understand the importance of taking care of our forests from the start. The core principle of ensuring harvest doesn't exceed growth guarantees a sustainable supply of timber.

Our team at The Woodsmiths is pioneering a new way of thinking when it comes to benchtop surfaces. Timber

provides a beautiful surface that will make any interior stand out, it gives a focal point to any kitchen, bathroom or living area, however the benefits of timber go further than that. Trees are one of the main stores of carbon and will hold this even after it has been harvested. This means your benchtop is holding CO₂ that would otherwise be in the atmosphere.



Custom Tops

Solid Wood surfaces crafted to a bespoke design, timber and finish. The grain and character of timber distinguishes your interior as unique. These tops are crafted from 'milled sawn' timber. This offers customization of lamination width and top thickness.

Laminating: This is all done in house and tops are grain matched and joined in a 'full stave' configuration. This is a seamless construction method resulting in a high-end timber panel. Typical lamination width is 40mm however this can be anything up to 90mm under our warranty.

Thickness: 20mm is the thinnest top we manufacture, and this must be completely supported. From this we can do any thickness up to 150mm solid. 40mm is our standard thickness.



Recycled Rimu, Kitchen & Interior Co.



American Oak, Detail by Davinia Sutton

Finger Jointed Tops

Finger jointed tops are constructed from 40mm timber laminations just like our standard tops, but the laminations aren't made from one full length piece of timber. Instead, there are shorter timber pieces end jointed with European precision finger joints to create one long lamination.

What are the advantages with Finger Jointed Tops?

- 🌀 **Eco Friendly:** With shorter lengths used there is less wasted timber, defects can be cut out and all clear timber can be made use of.
- 🌀 **Cost Effective:** These tops are significantly more economical compared to full stave tops of the same timber.
- 🌀 **Fast:** With these tops being stocked as pre-laminated panels, shorter lead times are possible.

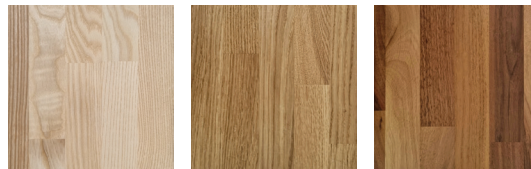

Ash

Oak

Walnut

Sheet Sizes: 5450L x 1280/760W x 40/30mmT



THE WOODSMITHS

Eco Bamboo Tops

Laminated Bamboo Bench Tops are very hard and durable and are our most cost-effective benchtop option. The fast growing bamboo is FSC certified, and we have a large range of sheets for any sort of project.



Sheet Sizes:

- 4200L x 720W x 30/40mmT
- 3600L x 1250W x 30/40mmT
- 3000L x 1250/720W x 30/40mmT
- 2440L x 1250W x 19/30/40/60mmT
- 2440L x 720W x 30/40mmT



Our timber coatings

Hi-Build Resin Finish: Our original signature timber coating & the most durable available anywhere. Available in a gloss, satin and matt finish. Even softer timbers such as Macrocarpa become much stronger with this coating. It is a thick layer of approximately 2-3mm protecting the timber from the wear and tear of a busy kitchen. Covered by a 10 year warranty.

G4 Finish: Developed by Kings woodworking, The Woodsmiths are the sole owners & appliers of this finish nationally. Although it is a different application, its properties are very similar to the Resin and covered with the same warranty. It is better suited to benchtops that finish flush with another surface as it is a thinner coating so we can finish the top to the exact dimension needed.

Lacquer Finishes: We use a very wide range of lacquer finishes, all applied in our own spray booth. This includes two pack polyurethane, water based and UV resistant products. Two pack lacquer finish is covered by a 5-year warranty.

Oil Finish: This offers a more natural tactile finish that is generally more matt than our other coatings. Available in various shades & colours. Covered by a 5-year warranty.



Maintenance and FAQ's

Resin & G4 Finishes

- ⦿ **No regular maintenance is needed.** Scratches can be buffed out with fine steel wool and wax reapplied to restore it to its original finish. This can be done repeatedly over the lifetime of the top. Wax is available for purchase on our website.
- ⦿ **Heat Resistance:** This surface is highly heat resistant. Boiling water is fine, however we recommend that heat resistant mats, tiles, glass or marble should be used where hot cups, pots and pans are used. The G4 has slightly more heat resistance than resin.
- ⦿ **Cleaning:** All standard non-abrasive cleaners can be used. We recommend using a microfibre cloth, spray & wipe cleaner or warm water. The Resin is highly resistant to all household cleaners, chemicals, solvents and bleaches, virtually stain-proof!
- ⦿ **Water Resistance:** This finish is 100% waterproof unless the seal is cracked or broken.

Lacquer Finish

- ⦿ **No regular maintenance needed.** This is a thin coating that is not suited to high wear areas. It is mostly used on bar caps, shelves and tables. This cannot be repaired on site.

Oil Finish

- ⦿ **This finish requires regular maintenance coats.** The frequency will depend on wear & tear. For the first year it is needed every 2 months and then in following years every 6 months. Oil is available for purchase on our website.
- ⦿ **Water Resistance:** Both the Lacquer and Oil Finishes are water resistant, any water should not be left on the surface and dried as soon as possible. Marking can occur if water is left on the surface for a long period of time.



The Process



Quoting: Email us your sizes and preferred timber and finish. Details such as sink and hob cut-outs, seen edges, overhanging areas should be included.



Ordering: Our team will manufacture the benchtop including cutting the cut-outs and fitting the sink (it is best to send the sink directly to us when ordering). Any waterfall ends & corner joins will be done in-house unless a site join is required.



Site measure: This is typically done by the joiner although we can offer this service if required.



Installation: Instructions and hardware are sent with each benchtop along with a homeowner care kit, instructions and the warranty card (if applicable) for the client. We can also install throughout Auckland and Northland.





THE WOODSMITHS

Solid Surface Tops

We are approved fabricators of HIMACS, Corian and Staron surfaces. We place extra care on customer service and project management excellence allowing us to complete projects for homeowners, hospitality and commercial projects of a wide scope.



Vanities

Timber vanities are a great way to include the warmth of nature when renovating or building a new bathroom.

We have a range of standard designs that can be easily purchased off our website. Scan the QR code to view these.



Custom Design Vanities

We have worked with designers NZ wide on bespoke creations for vanities. Send us your ideas and designs and we'll be happy to help!





THE WOODSMITHS

Solid Wood Doors

Solid Wood doors are popular with fine detailing in classic kitchens or a simpler design for country or industrial styles. With limitless timber, profiles and finish options to perfectly suit your taste along with our 30 years of highest quality craftsmanship, choose The Woodsmiths to create your dream kitchen!

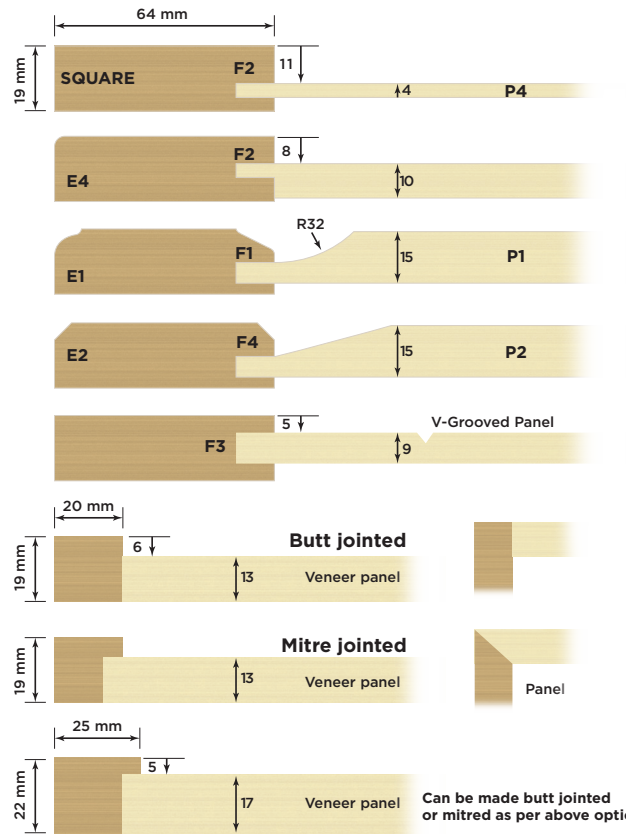

Aluminium Doors

Aluminium framed glass doors are very popular in modern kitchen designs. TrimTek aluminium framed doors are currently available in three different profiles and two different finishes.

The range includes Aluminium Frame and Glass Panel Doors, Bifolds and Sliders. We also offer black anodised frames for our Squareline and Fineline profiles. Any of the profile frames can be powdercoated with one of the Dulux or Interpon colours.

We offer a large range of glass options including Clear, Etchlite, Reeded, and Screen printed. Drilling for hardware is a free service we offer and we also supply all hardware as required.

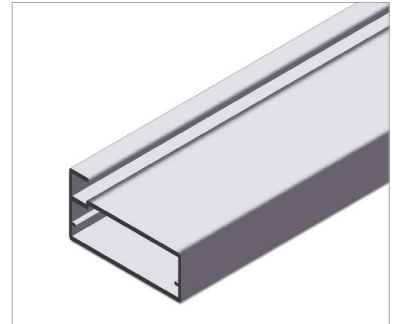

FINELINE TF50 - 50 X 20mm

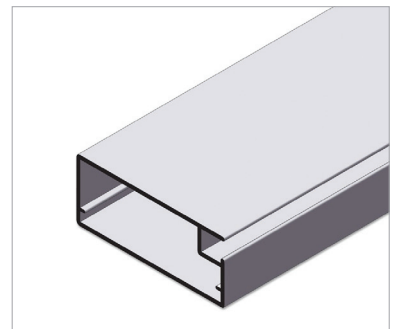

BROADLINE TB50 - 50 X 20mm

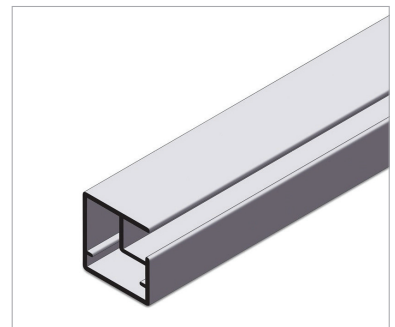

SQUARELINE TS20 - 20 X 20mm





THE WOODSMITHS

Shelving

The Woodsmiths shelves are the easiest way to transform your interior! Our standard floating shelves are easy to order and install. Scan the QR code to view these and watch the installation video.



ECO BAMBOO 40mm



FINGER JOINTED EURO OAK 40mm



FINGER JOINTED EURO WALNUT 40mm

Custom Shelving

Creating solutions for custom shelving requirement is our specialty, in both residential and retail interiors we can create a design specifically for your project.



HK Kitchens



Fluid Interiors

Stair Treads, Balustrades & Handrails

The durability, warmth, and feel of solid wood stair treads make it an excellent choice for commercial and residential properties. Just let us know your measurements and requirements, and we can give you a quote.

All stair treads, landings, balustrades and handrails are custom made to any size and design.

All stairs are finished with a two pack polyurethane or oil and can be stained to a client's particular taste.



Walnut treads



Solid 90mm treads



Apartment - Full USA Oak Staircase

We can rebate for steel work, groove for LED lighting, rebate and supply anti-slip insert.



THE WOODSMITHS

We offer a large selection of timbers to choose from to get the right look and feel for your property.

We also manufacture custom fins and screens for commercial or residential interiors. We can help ensure consistency for your project by supplying all timberwork needed.



L Shaped Treads

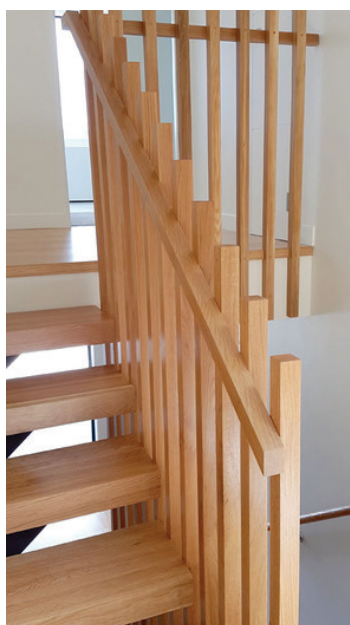

Balustrades & Fins

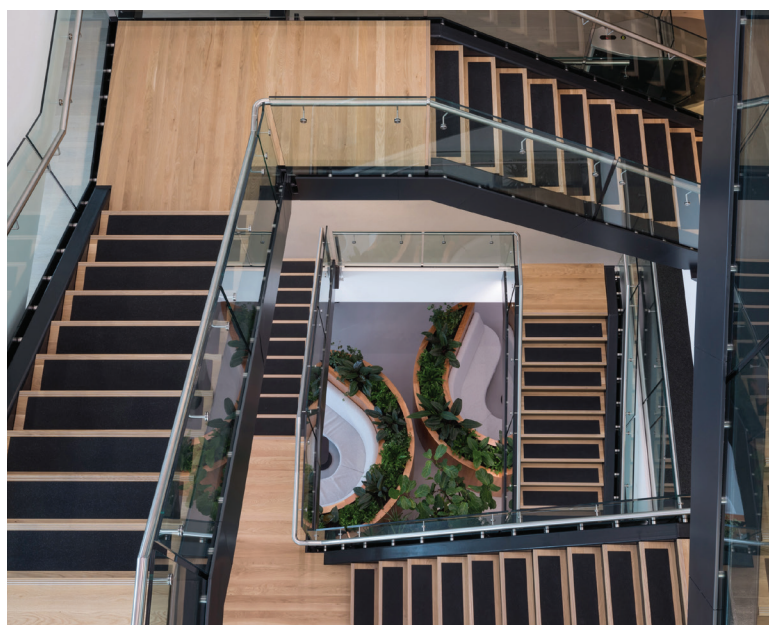

Commercial - USA Oak

Recommended Timbers (Wood Stains also available)

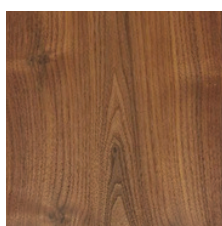

Walnut

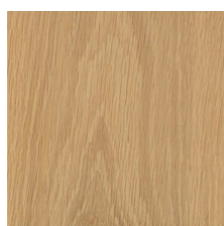

USA Oak

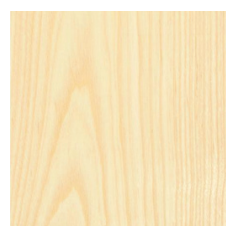

USA Ash

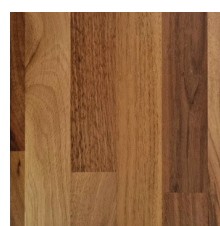

Finger Jointed Walnut

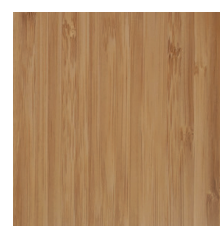

Eco Bamboo

Screens & Wall Linings

We manufacture feature screens and balustrades for residential and commercial interiors.

We typically use a 90 x 40mm slat which combines cost effectiveness and aesthetics to create a sturdy and visually stunning interior. We can also custom make these to a huge range of profiles to match with any design scheme.



Recommended Timbers: Oak, Walnut, Ash, Euro Beech





THE WOODSMITHS

Bespoke Tables

The Woodsmiths have the expertise and design talent to offer you bespoke timberwork for any design. Whether it be timber salvaged from a historic house or a 20,000-year-old swamp kauri slab, this can be incorporated into an enduring showpiece for your interior. Contact us for suggestions or to commission your own unique design.



Kitchens by Design



Butcher's Block

These units are very fine mobile kitchen work centres!

- ⊗ Solid 60mm thick end grain butcher's block top
- ⊗ All solid USA Oak or Walnut finish.
- ⊗ Other bespoke timbers available on request.
- ⊗ Great size, 800L x 600W x 910H.
- ⊗ Designer Castors and Handles



Optional:

- 1 or 2 Drawers
- 1 or 2 Shelves
- Wine Rack
- Slide out chopping board
- Knife organiser

Stain Colours



Whitewash



Sandstone



Graphite



Driftwood

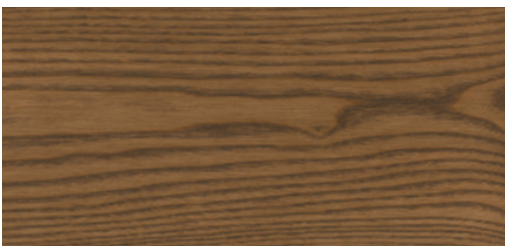

Mocha



Gunsmoke

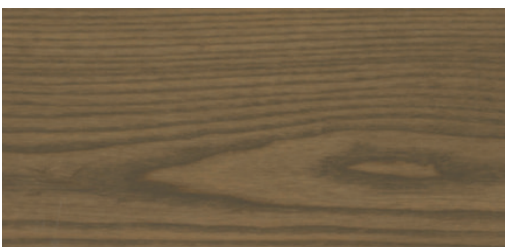

Hickory



Earth

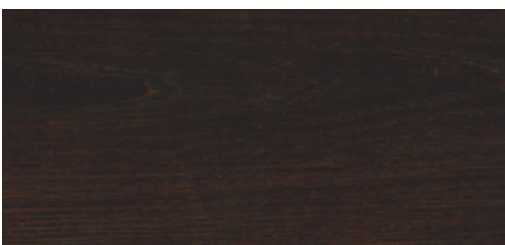

Cocoa



Midnight

Recommended timbers for staining: USA Oak, USA Ash, Bamboo.

All pictures are of American Ash wood, colours will vary depending on the timber chosen.

Timber Selection



Wenge



Zebrano



Teak



Cherry

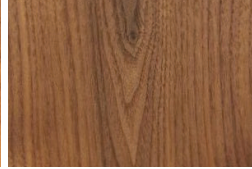

Walnut



Riverwood

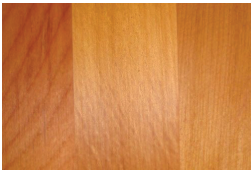

Matai

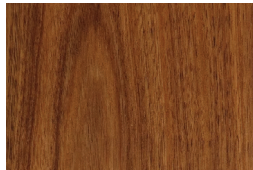

Tasmanian-Blackwood

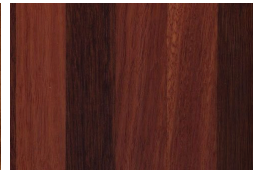

Jarrah

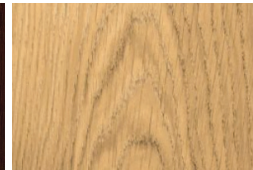

French-Oak



Maple

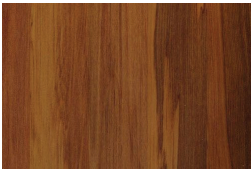

Rimu

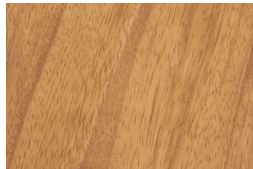

Iroko

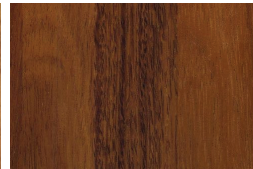

Kwila

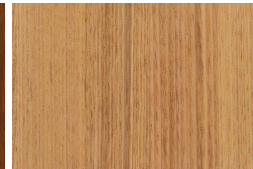

Australian-Oak

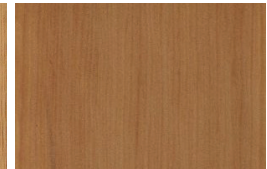

Swamp-Kauri

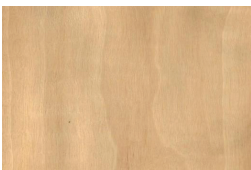

Anegre



NZ-Blackwood

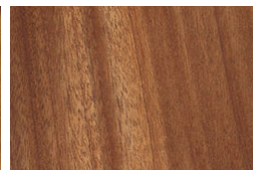

Mahogany

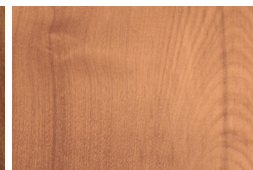

NZ-Beech



USA Oak

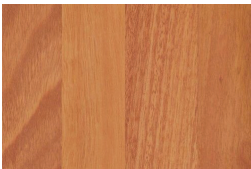

Saligna

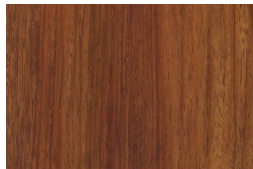

Rosewood

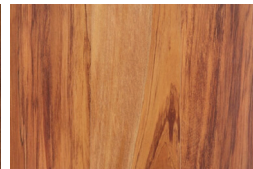

Yaka

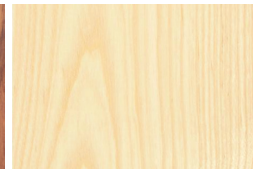

USA Ash

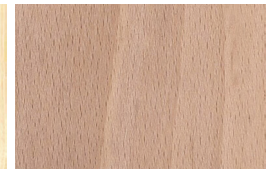

European Beech

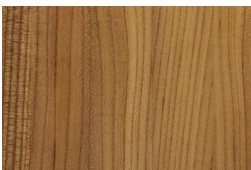

NZ Elm

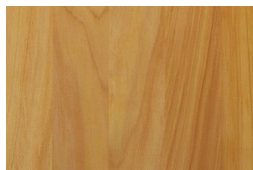

Macrocarpa



Island-Kauri

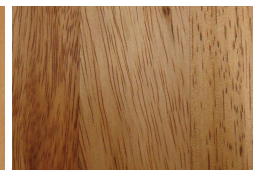

Akwa

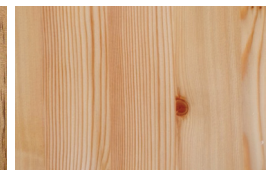

Siberian-Larch

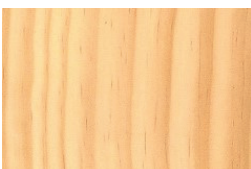

Pine

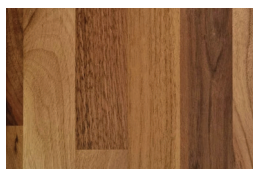

Finger-Jointed
Euro Walnut

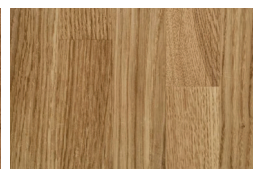

Finger-Jointed
Euro Oak

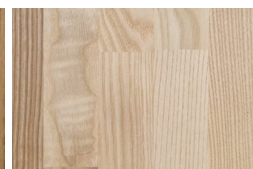

Finger-Jointed
Euro Ash



Bamboo



notes

A series of horizontal dotted lines for taking notes.



THE WOODSMITHS

0800 149 663

sales@woodsmiths.co.nz

www.woodsmiths.nz